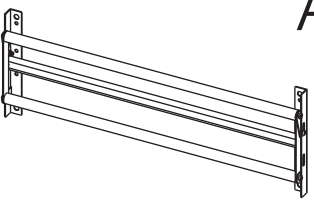
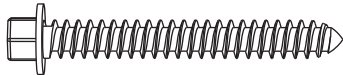
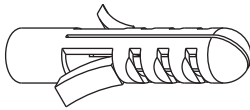
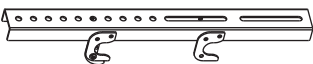
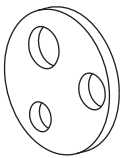
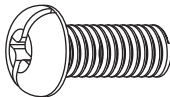
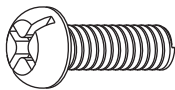
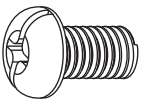

TKLA-8370 LCD TV BRACKET WALL MOUNTING MANUAL

CAUTION

1. Please read this manual carefully before installation and install by following the instructions.
Please keep this manual for future reference.
2. The manufacturer shall not be responsible legally for any damage to this product that results from accident, abuse, misuse, natural or personal disaster, or any unauthorized disassembly, repair or modification.
3. The design of the wall mount bracket is designed for installing and removing easily. The manufacturer shall not be liable to the damage of equipment and personnel injuries due to human factors or natural disaster, such as earthquake and hurricane.
4. The wall mount bracket must be installed by professional personnel.
5. At least two persons are needed to install or remove the product in order to prevent from any hazard caused by falling objects.
6. Please check carefully before installation the area where the wall mount will be installed.
 - ⊙ Avoid any place with high temperature or humidity or any place where will contact water.
 - ⊙ Do not install the product close to the vents of air conditions and avoid dusty and fummy place.
 - ⊙ Do not install on inclined wall and irregular surface. Please install on vertical wall.
 - ⊙ Do not install at place subject to vibrations and shocks.
7. Please make sure the space around the display is enough for installation.
8. Please make sure the wall is strong enough to sustain the weight at least four times the total weight of the display and the wall mount bracket.
Also make sure the wall could survive the earthquakes and other shocks. To ensure safety and avoid accidents, please choose the durable and highly safe place.
9. Do not modify any accessory, design or structure. Do not use broken parts. Contact the local distributors if there is malfunction or fault.
10. Tighten all screws (do not screw with excess force to prevent the screw, thread, wall mount bracket and the display from damage).
11. The maximum weight of panel display or plasma TV the wall mount bracket can take is 50kg (110lbs.)
12. Once the wall mount bracket is removed, the drilled holes and bolts will be left on the wall or the applied position.
Stains may occur after long term use.
13. To the extent of permitted by applicable law, the manufacturer disclaims any implied warranty of merchantability or fitness for a particular purpose. In no event will the manufacturer be liable to the purchaser or to the user of the product for any damages, expense, lost revenues, lost savings, lost profits, or any other incidental or consequential damages arising from the purchase, use or inability to use the product, even if the manufacturer has been advised of the possibility of such damages.
14. Specifications are subject to change without notification.

COMPONENTS

 <p>Wall Mount--1PC</p>	 <p>Hex Lag Bolt--4PCS</p>	 <p>Concrete Anchor--4PCS</p>	 <p>Bracket--1 Pair</p>
 <p>Washer--4PCS</p>	 <p>Screw: M6*15L--4PCS</p>	 <p>Screw: M5*15L--4PCS</p>	 <p>Screw: M6*8L--2PCS</p>

INSTALLATION

Step1 Install the Wall Mount(A) at the applied position

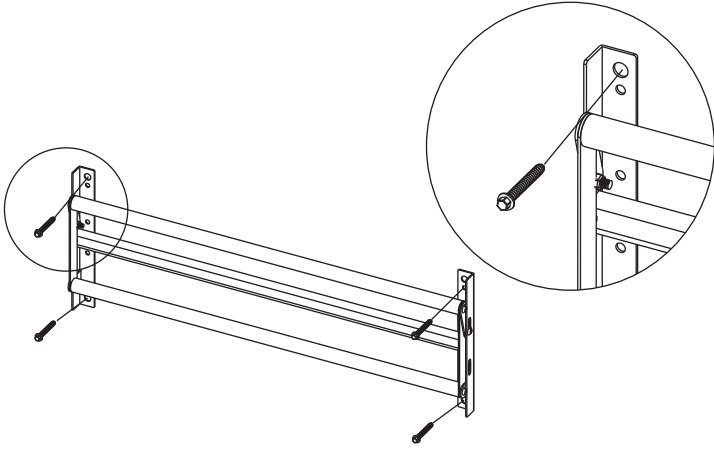

1. Wooden Wall or Drywall -drill a $\varnothing 5.0$ mm pilot hole at each location using an electric drill. Fix Wall Mount(A) to the wall using the Hex Lag Bolts(B).
2. Concrete- drill a hole at each location using a $\varnothing 8$ mm masonry bit. Remove any excess dust from the holes. Insert one Concrete Anchor(C) in to each hole. Fix Wall Mount (A) to the wall using the Hex Lag Bolts (B).
3. Do not release the Wall Mount(A) until all screws are secure.

 Please check the area where LCD TV will be installed carefully. Make sure it is strong enough to sustain the total weight of the display and wall mount kit. Do not install on irregular surface. The wall mount kit must be installed by professional personnel. At least two persons are needed to install or remove the product in order to prevent any accident.

Step3 Assemble the Bracket(D) with Wall Mount(A)

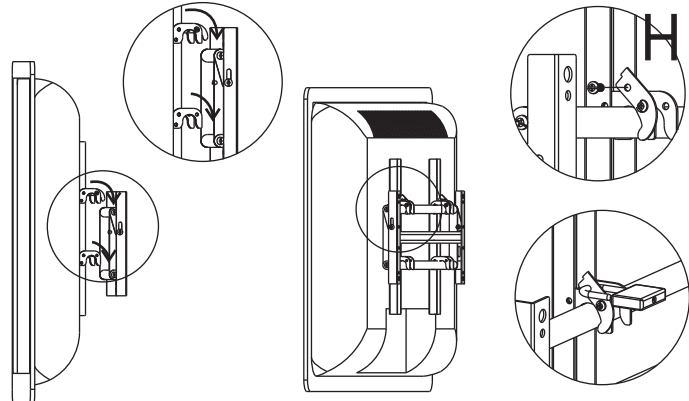

1. Hang the LCD TV assembled with the Bracket (D) on the Wall Mount (A) mounted on the wall.
2. Please notice that the safety hook on the Bracket (D) must hook on the Wall Mount (A) very firmly. Do not release the display until the hook have securely hooked onto the crossbars.
3. Move the safety hook located on each bracket into position and insert M6*8L Screw(H) into the hole on the safety hook to fix and to avoid having the display accidentally lifted from the mount.

 Please release the safety hook first before removing LCD TV from the Wall Mount (A). Do not pull LCD TV directly to prevent persons and equipment from damage. At least two persons are needed to remove the product.

Step2 Assemble the Bracket(D) with LCD TV

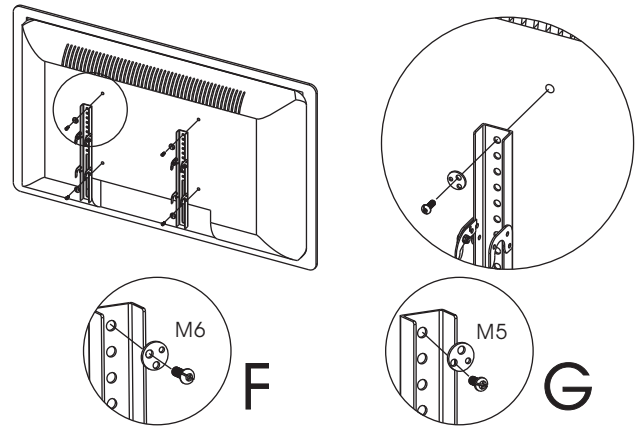

1. Take out screws F & G and choose the suitable screw which mostly match the VESA holes at the back of LCD TV. Then go through the matched hole on the Washer(E). (For example, if M6 screw is the matched screw, then it should go through the biggest hole on the washer(E).)
2. Place the LCD TV at flat place. Screw the Bracket (D) at the back of LCD TV with the matched screws. Make sure the screws are snug, but do not over-tighten.

 1. Screws F and G could go through the holes on the washer respectively.
2. The VESA holes at the back of different brands of LCD TV/Plasma TV might be different. If the screws do not match the VESA holes at the back of LCD TV, please contact your distributor.

Step4 Adjust the view angle for LCD TV

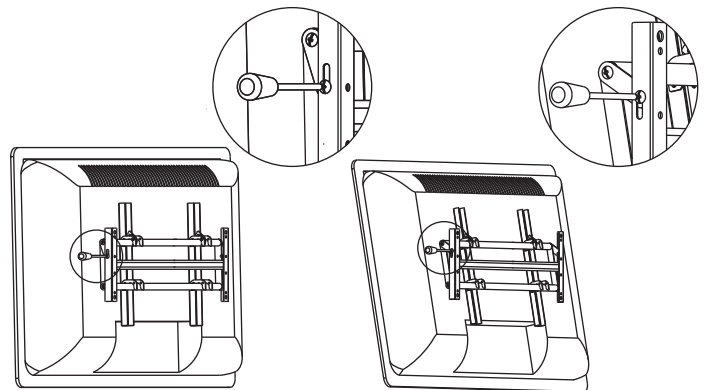

1. Use screw driver to loose the bolts at both sides.
2. Adjust the view angle of LCD TV to the angle you prefer. The Maximum adjustable angle is 10 degree.
3. Please tighten the bolts at both sides after adjustment in order to fix the optimal view angle.

 When adjusting the bolts, do not take out the bolts to prevent any damage. Please remember to tighten the bolts after adjustment in case of shocks. Check the bolts regularly. Tighten the bolts again if they become loose. Please contact the distributor if the condition is not improved.

TOOLS REQUIRED

- Crosshead Screw Driver
- Portable or Electric Drill
- 7mm Socket Wrench or Ratchet with 7 mm Socket
- 5.0mm Drill Bit for Wooden Wall or Drywall Installation
- 8.0mm Masonry Bit for Concrete Installation

DIMENSIONS

TKLA-8370 LCD TV Bracket

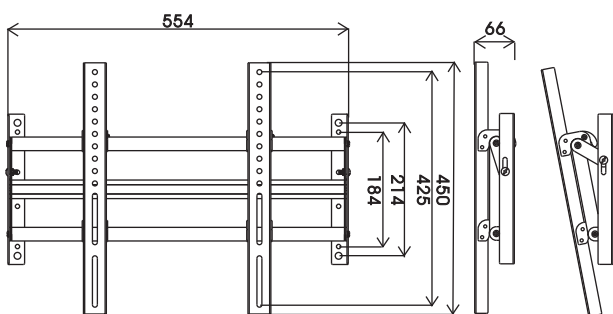

Unit: MM

TKLA-8420 LCD TV Bracket

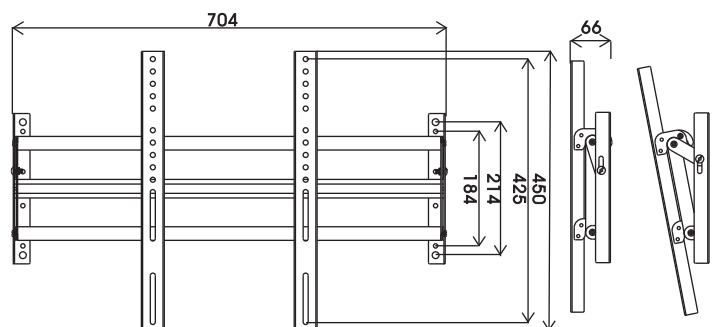

Unit: MM