

Space Generator Lcd Monitor Arm (Customized)

TKLA-6032C2



SPECIFICATION

Applicable Display	Monitor with VESA Standard Holes
VESA Standard	MIS-D
Max. Display Weight	10kg per monitor
Mounting Methods	Enhanced Desk Clamp Mount
Clamp Mount (Fits)	1~6.5cm Thick
Material Construction	Base: Steel; Arm: Aluminum; Pole: Steel
Surface Finish	Liquid Coating
Standard Color	Silver
Cable Manager	Yes
Arm Adjustments	Vertical Range 70.4cm
Display Adjustments	Left & Right 80° / 80° Clock Rotation 360°
Net Weight	2.8kg
Gross Weight	3.15kg
Packing Dimensions	L48.5cm X W18.2cm X H7.0 cm

Specifications are subject to change without notice for further improvement.

Features

Space Generator TKLA-6032C2 has foldable arm articulating flat panel mount.

Apply to two monitors with the pivot arms and offer mobility and flexibility.

Users can easily move up and down the monitor by using one simple tool to screw the nut on the arm.

Users are comfortable to watch the monitor no matter sitting or standing.

Easy steps installation fits in work place and home.

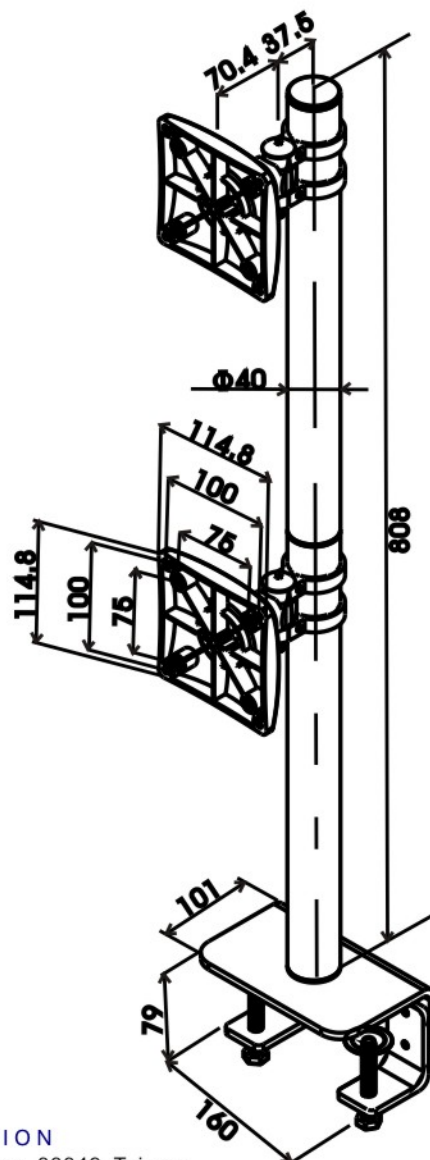

Unit:mm



FOGIM ENTERPRISE CORPORATION

No. 2-3, Chajhuan Rd., Gueishan Town, Taoyuan, 33349, Taiwan

Tel: +886-3-350-1837 Fax: +886-3-350-3730

Website: www.fogim-ent.com

E-mail: fo.gim@msa.hinet.net; info@fogim-ent.com